

AA2920A

BILEVEL STEP MOTOR DRIVER CONTROLLER HYBRID CIRCUIT



910 E. ORANGEFAIR LANE
ANAHEIM, CA 92801
(714) 992-6990
FAX (714) 992-0471
<http://www.anaheimautomation.com>
[email: info@anaheimautomation.com](mailto:info@anaheimautomation.com)

COPYRIGHT

Copyright 1997 by Anaheim Automation. All rights reserved. No part of this publication may be reproduced, transmitted, transcribed, stored in a retrieval system, or translated into any language, in any form or by any means, electronic, mechanical, magnetic, optical, chemical, manual, or otherwise, without the prior written permission of Anaheim Automation, 910 E. Orangefair Lane, Anaheim, CA 92801.

DISCLAIMER

Though every effort has been made to supply complete and accurate information in this manual, the contents are subject to change without notice or obligation to inform the buyer. In no event will Anaheim Automation be liable for direct, indirect, special, incidental, or consequential damages arising out of the use or inability to use the product or documentation.

LIMITED WARRANTY

All Anaheim Automation products are warranted against defects in workmanship, materials and construction, when used under Normal Operating Conditions and when used in accordance with specifications. This warranty shall be in effect for a period of twelve months from the date of purchase or eighteen months from the date of manufacture, whichever comes first. Warranty provisions may be voided if the products are subjected to physical damage or abuse.

Anaheim Automation will repair or replace at its option, any of its products which have been found to be defective and are within the warranty period, provided that the item is shipped freight prepaid, with RMA (return material authorization), to Anaheim Automation's plant in Anaheim, California.

TABLE OF CONTENTS

DESCRIPTION	2
PACKAGE INFORMATION	2
SPECIFICATIONS	3
BILEVEL DRIVE OPERATION	5
PIN DESCRIPTION	6
CLOCK INPUT SELECTION	10
HALF-STEP/FULL-STEP	12

DESCRIPTION

The AA2920 is a CMOS integrated circuit based hybrid step motor driver ideally suited for the design of 4-phase unipolar bilevel step motor drivers. This hybrid can be used to design **half-step** and **full-step** bilevel type drivers.

The basic function of this hybrid is to take input (i.e. clock and direction) signals and turn them into appropriate phase signals that are used to drive output transistors. In most applications, the end user simply adds a few components along with power transistors for the output stage. This results in low cost, compact, and reliable designs.

The AA2920 comes in a 34-pin hybrid package. Dimensions below are in inches.

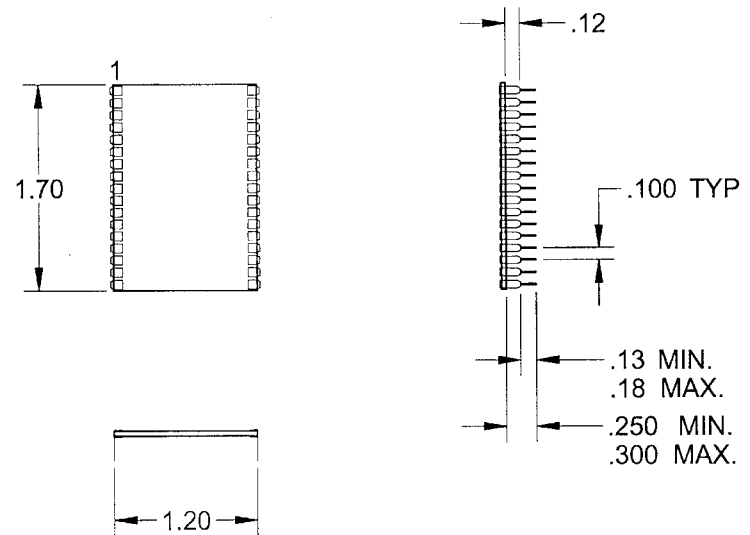

SPECIFICATIONS

PARAMETER	SYMBOL	LIMITS			UNITS
		MIN	TYP.	MAX	
Supply Voltage	Vdd	4.75	5.00	5.25	V
Input Logic High (Vdd=5.0V)	Vih		3.5	Vdd	V
Input Logic Low (Vdd=5.0V)	Vil	0	0.8		V
Operating Temperature (Ambient)	Ta	0	-	70	C
Storage Temperature	Ts	0	-	70	C
Power Dissipation			250		mW
Supply current			50		mA
Min. clock Pulse Width	twh, twl		15		usec
Propagation Delay Time (Clock to Output)	tpd	3.5		5	usec

AA2820 OUTPUT CHARACTERISTICS

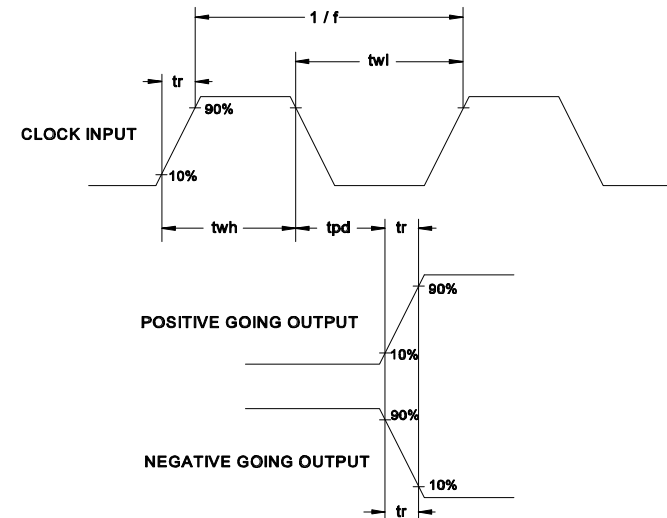
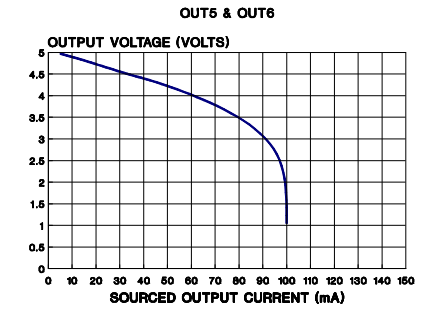
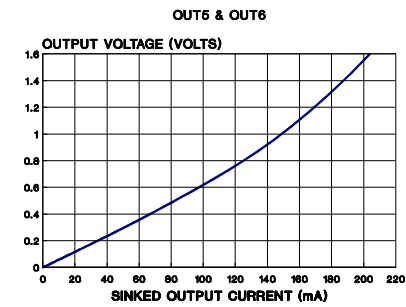
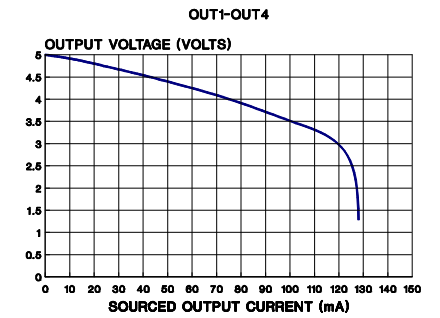
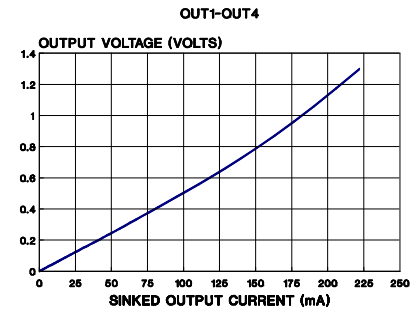

Figure 3: Input/Output Waveform Characteristics

BILEVEL DRIVE

The basic function of a step motor driver is to control the motor winding currents. Motor performance is determined by how fast the driver can increase and decrease the winding currents. A rapid rise in winding current is achieved by applying a high voltage directly to a motor. This rapid rise of current is also referred to as the "kick" or operating current. When a desired current level is reached, a low voltage is applied to maintain a suitable holding current level. When a motor winding is turned off, a rapid decrease in winding current is achieved by routing the energy in the collapsing field back to the power supply through a high voltage path. The high voltage supply furnishes the energy necessary to maintain motor output torque at high step rates thus providing high mechanical power output. The low voltage supply provides much of the current needed at low step rates and all of the holding current.

The efficiency of the bilevel drive makes for step motor performance that is far superior to that produced by L/R drives. Also, bilevel drivers do not use high frequency switching techniques as chopper drivers do. Consequently, they do not create the EMI, RFI, and motor heating problems that are associated with chopper drivers.

AA2920A Operation

Each time the AA2920 receives a clock signal, the phase outputs change state. When a phase output turns on, a high voltage output also turns on. This high voltage output is used to turn on a high-side switch. The high voltage output will stay on until the chip gets a reset signal. In Figure 4, OUT1 turns on when the CLOCK input goes low. OUT5 turns on at the same time. OUT5 stays on until the reset input, R13 goes low. The waveforms in Figure 4 are for half-step operation. In half-step operation, the phase outputs are on for three clock cycles. The high voltage output will turn on the first two of these cycles. If the reset input never goes low, the high voltage output will stay on. In full-step operation, each phase output is on for two clock cycles and the corresponding high voltage output will turn on at the beginning of each clock cycle.

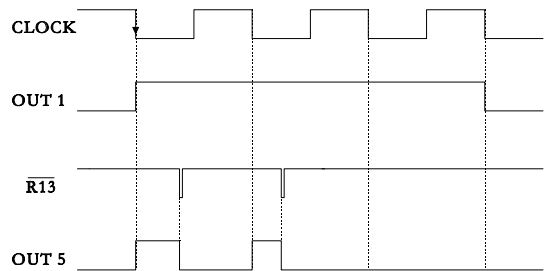

Figure 4: High Voltage Output (OUT5) vs. Reset (R13) and OUT1.

AA2920A PIN DESCRIPTION

<u>PIN</u>	<u>NAME</u>	<u>DESCRIPTION</u>
1	Vdd	Power (+5Vdc)
2	VHV	Driver High Voltage
3	B24	Base Output for High Voltage Darlington Transistor. (Phase 2 and Phase 4)
4	E24	Emitter Output for High Voltage Darlington Transistor. (Phase 2 and Phase 4)
5	B13	Base Output for High Voltage Darlington Transistor. (Phase 1 and Phase 3)
6	E13	Emitter Output for High Voltage Darlington Transistor. (Phase 1 and Phase 3)
7	HV OFF	Grounding this pin will disable the High Voltage.
8	Reg A	Resistor Network Useful in producing an external 5Vdc supply with a LM317 Voltage Regulator.
9	1B01	Base Driver for Phase 1 (Output Impedance of 500 Ohms.)
10	2B01	Base Driver for Phase 1 (Output Impedance of 150 Ohms.)
11	1B03	Base Driver for Phase 3 (Output Impedance of 500 Ohms.)
12	2B03	Base Driver for Phase 3 (Output Impedance of 150 Ohms.)
13	1B02	Base Driver for Phase 2 (Output Impedance of 500 Ohms.)

AA2920A PIN DESCRIPTION (cont)

<u>PIN</u>	<u>NAME</u>	<u>DESCRIPTION</u>
14	2B02	Base Driver for Phase 2 (Output Impedance of 150 Ohms.)
15	1B04	Base Driver for Phase 4 (Output Impedance of 500 Ohms.)
16	2B04	Base Driver for Phase 4 (Output Impedance of 150 Ohms.)
17	Vss	0Vdc
18	Vss	0Vdc
19	POTLS	Kick Current Potentiometer Low Side.
20	R24	Sense Resistor Input for Phase 2 and Phase 4. (Signal feeds into Comparator of Phase 2 and Phase 4)
21	POTCOM	Kick Current Potentiometer Common (Wiper).
22	R13	Sence Resistor Input for Phase 1 and Phase 3. (Signal feeds into Comparator of Phase 1 and Phase 3)
23	POTHS	Kick Current Potentiometer High Side.
24	ON/OFF	Enables Driver Output (Pulled High) and Disables Driver Outputs (Pulled Low).
25	(04IN)HS/FS	<i>Phase 4 in Phase Mode</i> or Enables Half-Step(Pulled High) and Full-Step(Pulled Down) in <i>Clock and Direction Mode</i> .

AA2920A PIN DESCRIPTION (cont)

<u>PIN</u>	<u>NAME</u>	<u>DESCRIPTION</u>
26	R2527	Pull-Up or Pull-Down Resistors used in conjunction with with <i>Phase Mode</i> or <i>Clock and Direction Mode</i> .
27	(03IN)DIR.	<i>Phase 3 in Phase Mode</i> or <i>Direction Control</i> for clockwise and counter clockwise motion selection.
28	C/P(OSCOUT)	Selects Clock Mode (Pulled Up) or Phase Mode(Pulled Down). <i>Note this pin is also the Test Point for the Internal Oscillator = 1MegHz ±10%.</i>
29	(02IN)CCW	<i>Phase 2 in Phase Mode</i> or Clock Input in Two Clock Mode selection for <i>Counter Clock Wise</i> motion.
30	R2931(IP)	Pull-Up or Pull-Down Resistors used in conjunction with with <i>Phase Mode</i> or <i>Input Polarity</i> for Negative and Positive Polarity in <i>Clock and Direction Mode</i> .
31	(01IN)CLOCK	<i>Phase 1 in Phase Mode</i> or <i>Clock Input</i> in <i>Clock and Direction Mode</i> .
32	Step Out	Step Clock Output
33	RUN/STOP	Enables Outputs (Pulled High) when running and Disables Outputs when Pulled Down.
34	Vdd	Power (+5Vdc)

CLOCK INPUT SELECTION

There are three three clocking methods for the and AA2920A. The C/P input is used to select CLOCK inputs or PHASE inputs. The IP input is used to select positive or negative going inputs. See Table 1.

INPUT CLOCK SELECTION	C/P	IP
+ GOING CLOCK INPUTS	1	0
- GOING CLOCK INPUTS	1	1
POSITIVE TRUE PHASE INPUTS	0	0
NEGATIVE TRUE PHASE INPUTS	0	1

TABLE 1: Clock Input Selection.

CLOCK and DIRECTION: Pulses applied to the CLOCK input will cause the motor to step in the clockwise direction if the DIRECTION input is logic "1". Pulses applied to the CLOCK input will cause the motor to step in the counterclockwise direction if the DIRECTION input is logic "0". Figure 7 shows Clock and Direction signals which will make 5 steps in the clockwise direction and 5 steps in the counterclockwise direction.

CLOCK and CCW: Pulses applied to the CLOCK input cause the motor to step in the clockwise direction. Pulses applied to the CCW input cause the motor to step in the counterclockwise direction. Pulses should NOT be applied to both of these inputs at the same time. The input which is not being used should be held low when using positive going clock inputs, or held high when using negative going clock inputs. Figure 7 shows Clock and Direction signals which will make 5 steps in the clockwise direction and 5 steps in the counterclockwise direction.

PHASE INPUTS: Half-step or Full-step sequence phase inputs may be used to synchronize multiple axes. Only the phase input sequences shown in Figure 8 may be used. The phase input sequences in Figure 8 produce clockwise motor movement. The phases may be reversed to obtain counterclockwise motor movement. Positive or Negative true phase inputs may be used.

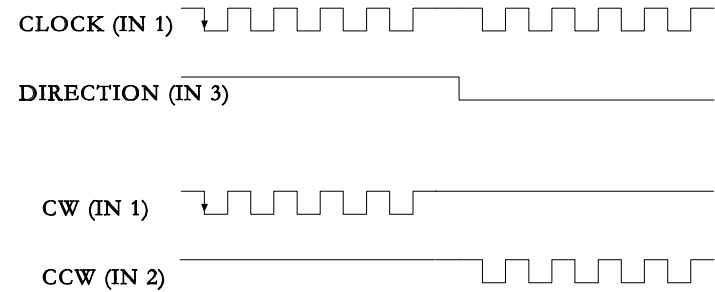

Figure 7: The CLOCK and DIRECTION signals are equivalent to the CW and CCW signals

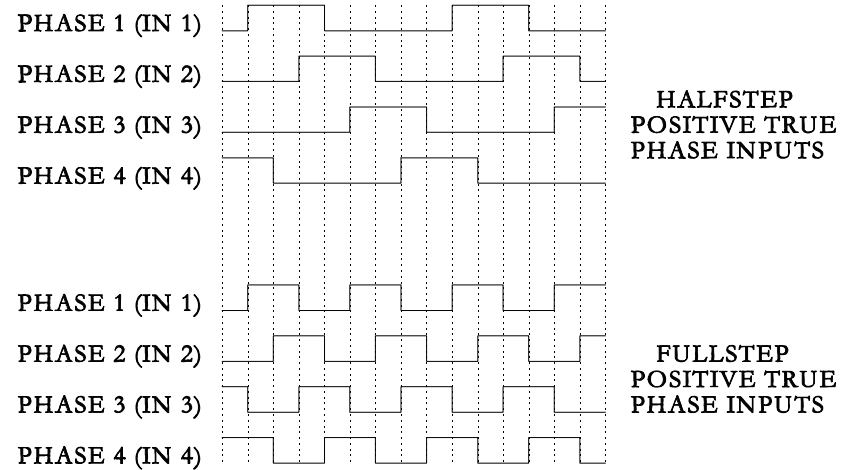

Figure 8: Phase Input Sequence

HALF-STEP/FULL-STEP

NOTES

The AA2920A operates a motor in either half-step or full-step operation. In half-step mode, the motor is stepped by alternately energizing one phase, and then two phases of the motor. With a 1.8 degree motor (200 steps/rev), half-step mode will provide 400 steps/revolution. Table 2 below shows the sequence for half-step.

PHASE 1	PHASE 2	PHASE 3	PHASE 4	
1	0	0	0	CCW
1	1	0	0	
0	1	0	0	
0	1	1	0	
0	0	1	0	CW
0	0	1	1	
0	0	0	1	
1	0	0	1	

Table 2: Half-step Phase Sequence 1=ON, 0=OFF

In Full-step mode, there are always two phases on at a time. The motor is stepped by turning off a phase and turning on the opposite phase (i.e. - turn phase 1 off and turn phase 3 on). A standard 1.8 degree motor will provide 200 steps/revolution in full-step mode. The phase sequence for full-step is shown in figure y2.

PHASE 1	PHASE 2	PHASE 3	PHASE 4	
1	1	0	0	CCW
0	1	1	0	
0	0	1	1	CW
1	0	0	1	

Table 3: Full-step Phase Sequence 1=ON, 0=OFF

NOTES



A N A H E I M A U T O M A T I O N

**910 E. Orangefair Lane
Anaheim, CA 92801
(714) 992-6990
fax (714) 992-0471**